

ASSEMBLY INSTRUCTIONS

Assembly of a LOKRING® NAV connection

VULKAN LOKRING

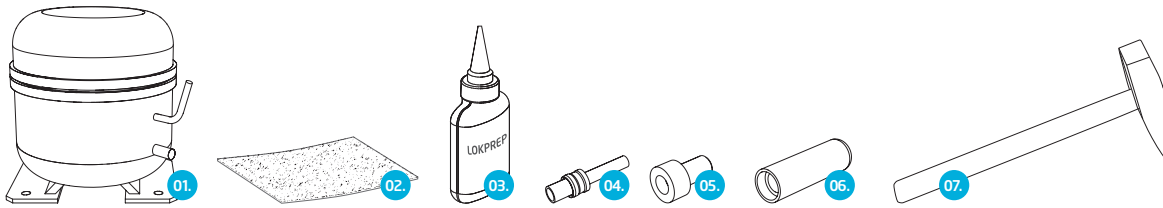

01. Compressor 02. Emery cloth 03. LOKPREP 65G 04. NAV connection 05. NAV assembly insert 06. NAV assembly tool 07. Hammer

1 The compressor stub length (X^1) must be straight, no longer than the flared section (Y^1) of the NAV connection (04) and not shorter than the length of the LOKRING that is to be used (Y^2) + 2 mm.

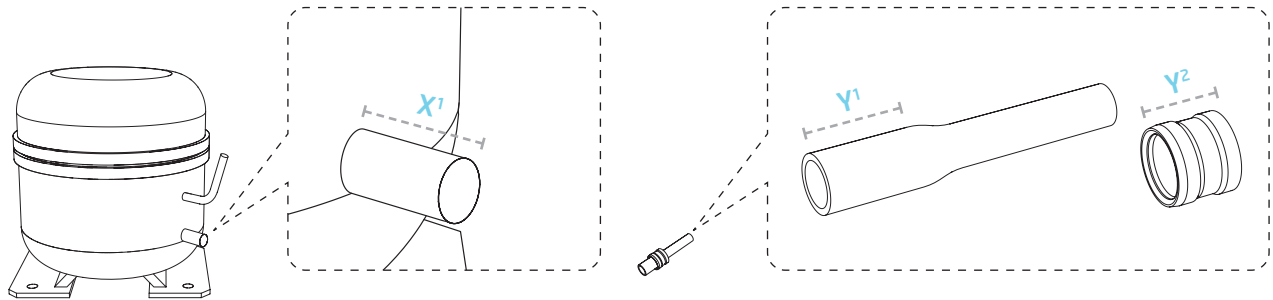

2 Clean the compressor stub length (X^1) in a rotational motion to ensure that it is clean and free from paint or other surface impurities.

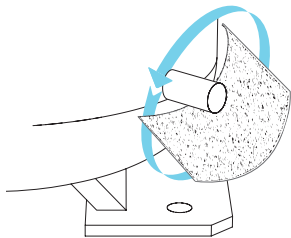

3 Apply LOKPREP 65G (03) onto the entire circumference of the compressor stub length (X^1), up to the cut edge. Respect the curing time of the LOKPREP 65G (03).

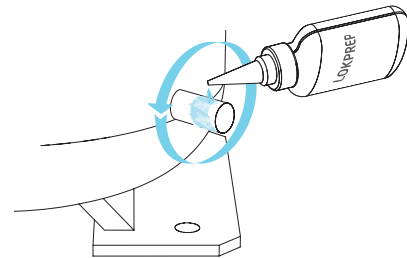

4 **1** Determine the outer tube diameter \varnothing of the compressor stub (X^1) using a digital caliper. Select the appropriate NAV connection (04) and NAV assembly insert (05) according to the outer diameter of the compressor stub (X^1). Push the NAV connection (04) onto the compressor stub (X^1) and insert the NAV assembly insert (05) into the NAV assembly tool (06). Chamfer of the LOKRING must be oriented towards the compressor housing (01). Ensure that NAV connection (04) is touching the compressor housing (01).

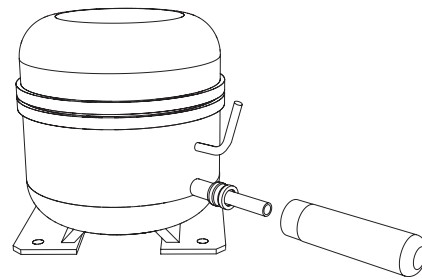
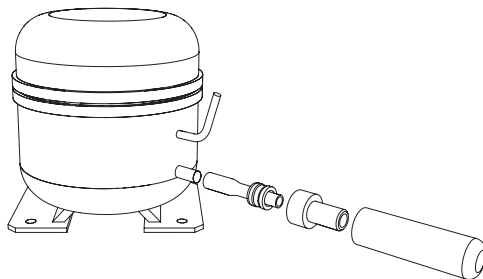

5 Strike the NAV assembly tool (06) with a hammer (07) until the LOKRING of the NAV connection (04) reaches the compressor housing (01).

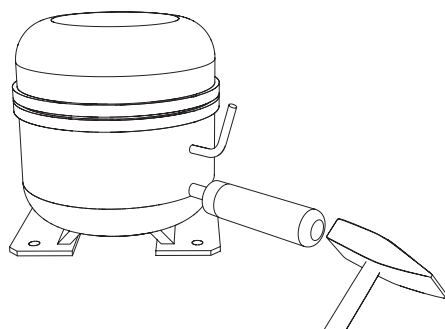

6 Carry out the LOKRING assembly with due regard to the assembly instructions for LOKRING connections type 00 at www.vulkan.com.

